

WE ❤️ VETERANS PIN DESIGN CHALLENGE

DESIGN GUIDELINES

Above all else we encourage you to participate and here are some tips and guidelines to keep in mind when designing your pin. Points are awarded for more than just an expertly crafted 3D model, and if you submit a model that doesn't comply with every guideline below, you will not be disqualified. If you are new to 3D design, check out the video tutorials in the digital tools section of the challenge site to help you get started. To see an example of how 3D entries are displayed in the gallery with an image and STL file, please visit a previous challenge gallery, such as:

<https://www.futureengineers.org/twoforthecrew/gallery>

GOOD LUCK!

GOOD!

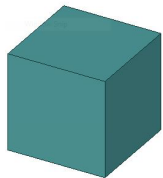

BAD!

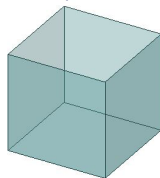

BAD!

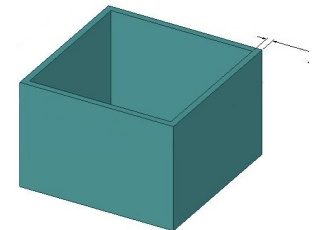
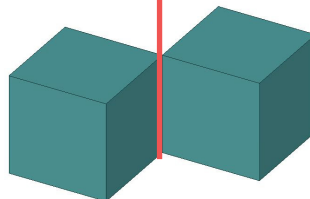

Your 3D model should be solid geometry. For example, the model on the right has no top surface and zero wall thickness. This is not 3D printable for the prize. Most CAD programs make solid models, so you're probably fine! But if in doubt, upload your STL file to Meshmixer and check.

No shared single edges (lines) like above.

Minimum recommended wall thickness for your model is 1.5 mm.



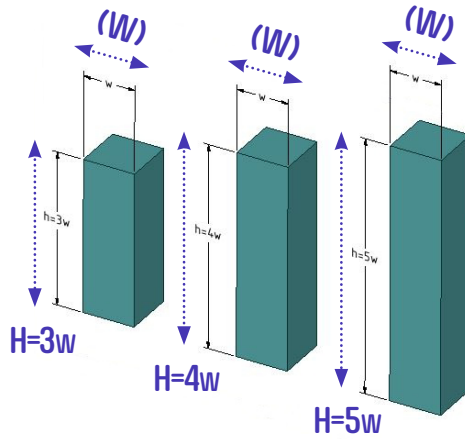
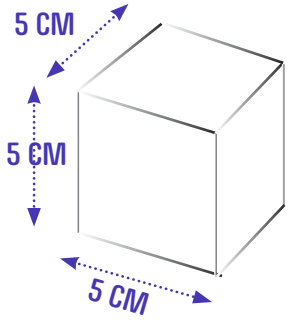

All pins will be scaled down when printed to be limited to approximately 5cm in width, length, or height.

If you need to use support structures, a general guide is to have a height to width aspect ratio of 4:1 or less.

Print-in-place designs are allowed and welcome.

SNAP FIT =

A part that is designed to press or snap into another part and does not move.

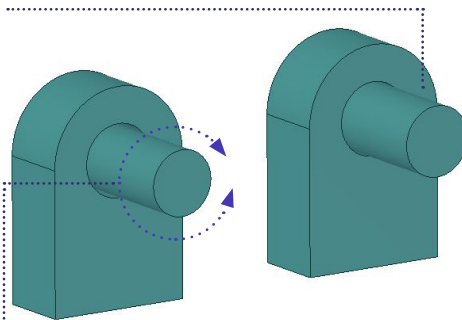

SLIP FIT =

A part that is designed to rotate or slide within another part.

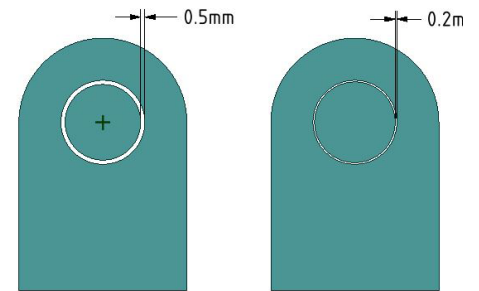

SLIP FIT

SNAP FIT

Multi-part assemblies are allowed and can be assembled by Future Engineers before distributing the design, however print-in-place assemblies are encouraged.

Slip fit guidelines are: .5mm on every side. (1 mm diameter difference if an axle) Snap fit guidelines are: .2mm on every side (.4mm diameter difference if an axle).

PIN IT!

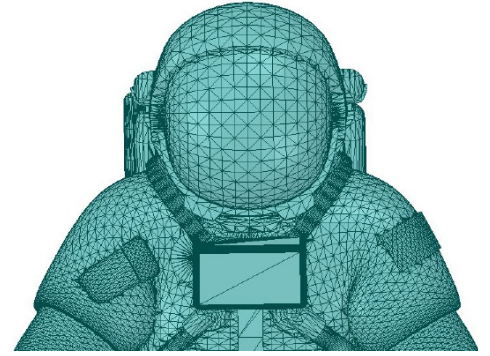
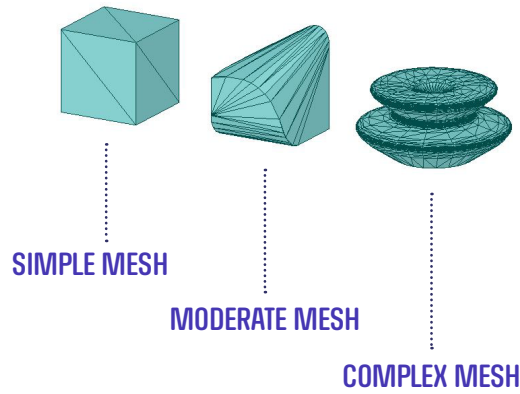

The finalist designs will be 3D-printed and glued to bar pin backs in order to be distributed to veterans. Please ensure that there is an area on the back of your 3D design suitable for gluing the pin backs. Sample pin backs can be seen [here](#) and [here](#).

The maximum STL File size is 20MB. STL files are mesh geometry (triangles). A simple box may be a few KB, whereas a complex model that requires a mesh with more triangles will be a larger file. To allow for advanced designs, we have given you a large file size limit!

For example, this mesh is complex, but is under 20MB if exported properly. To change the resolution of your STL file export, you can upload your STL file to Meshmixer and re-export it using the **STL Binary Format** to reduce file size.

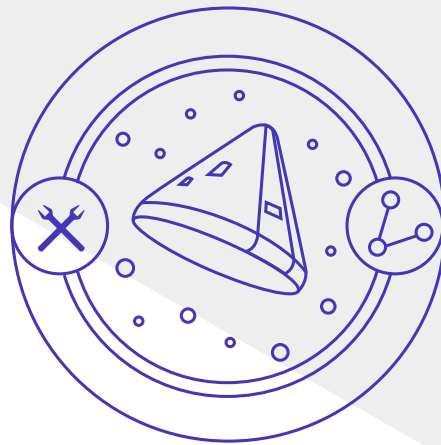

Just a reminder that we reserve the right to tweak, edit, or recreate all submissions for prize fulfillment and to distribute the pins to veterans. It's in our [Official Rules](#), but we wanted to say it again!

WE CAN'T WAIT TO SEE YOUR PIN DESIGN!

